

# Straddle Leg Electric Stacker WS10SS WS12SS WS15SSL Operations Manual

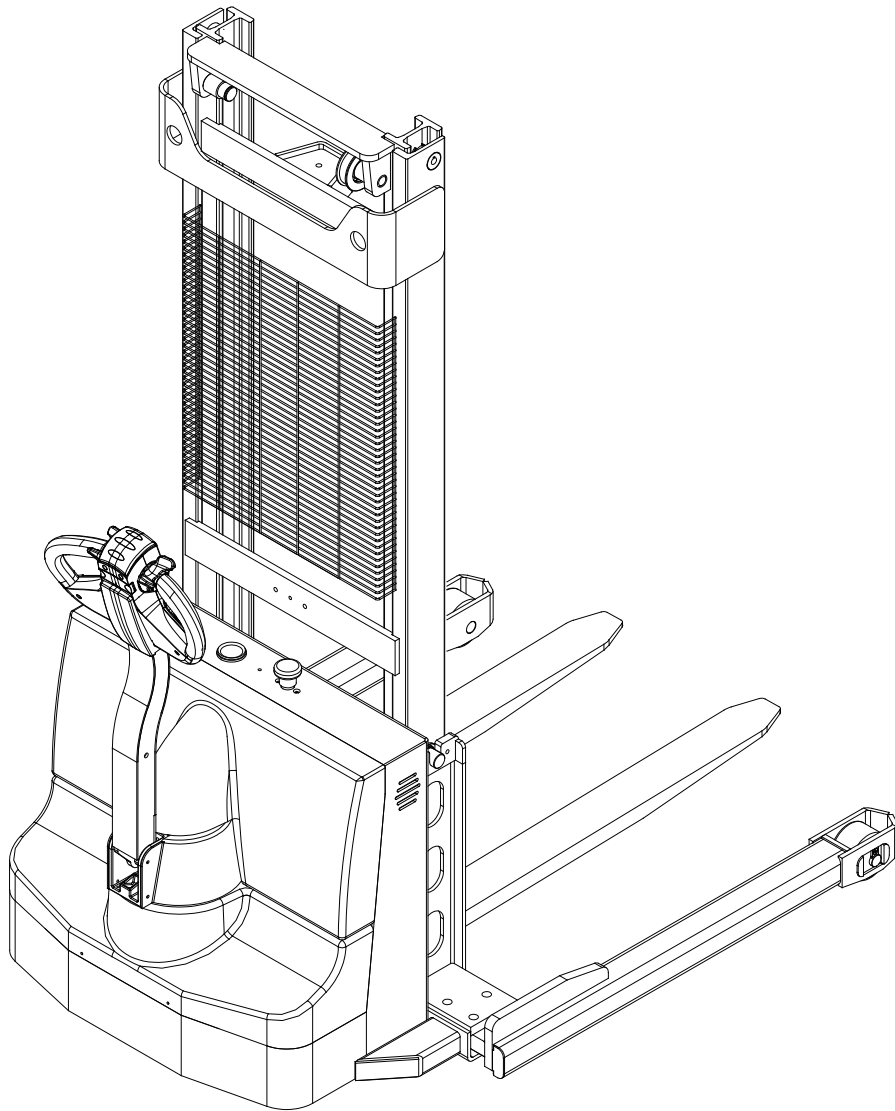

## Foreword

The present original operating instructions are designed to provide sufficient instruction for the safe operation and maintenance of the truck. Please be sure to read this operator manual carefully if you are operator or are in charge of the truck, before you operate and service the truck. Only in this way can you protect yourself and make the truck play a role as much as possible.

Our trucks are subject to ongoing development, so maybe there are some differences between your product and the description in this manual. And the operator manual details will be different because of customer's special requirements.

If you have any questions, please keep in touch with the sales department or let the dealer know.

**ALL RIGHT RESERVED COPYRIGHT**

**WARNING!**  
**TO PREVENT SERIOUS RISK OF INJURY TO  
YOURSELF AND OTHERS OBSERVE THE  
FOLLOWING SAFETY INSTRUCTIONS.**

These trucks may become hazardous if adequate maintenance is neglected. Therefore, adequate maintenance facilities, trained personnel and procedures should be provided.

Maintenance and inspection shall be performed in conformance with the following practices:

1. A scheduled planned maintenance, lubrication and inspection system should be followed.
2. Only qualified and authorized personnel shall be permitted to maintain, repair, adjust, and inspect truck.
3. Before leaving the truck:
  - Do not park the truck on an incline.
  - Fully lower the load forks.
  - Press the emergency brake switch .
  - Set the key switch to the "OFF" position and remove the key.
4. Before starting to operate truck:
  - Be in operating position
  - Place directional control in neutral
  - Before operating truck, check functions of lift systems, directional control, speed control, steering, warning devices and brakes.
5. Avoid fire hazards and have fire protection equipment present. Do not use open flame to check lever, or for leakage of electrolyte and fluids or oil. Do not use open pans of fuel or flammable cleaning fluids for cleaning parts.
6. Brakes, steering mechanisms, control mechanisms, guards and safety devices shall be inspected regularly and maintained in legible condition.
7. Capacity, operation and maintenance instruction plates or decals shall be maintained in legible condition.
8. All parts of lift mechanisms shall be inspected to maintain them in safe operating condition.
9. All hydraulic systems shall be regularly inspected and maintained in conformance

with good practice. Cylinders, valves and other similar parts shall be checked to assure that "drift" has not developed to the extent that it would create a hazard.

10. truck shall be kept in a clean condition to minimize fire hazards facilitate detection of loose or detective parts.

11. Modifications and additions which affect capacity and safe truck operation shall not be performed by the customer or user without manufacturers prior written approval. Capacity, operation and maintenance plates or decals shall be changed accordingly.

## Catalog

<b>Correct use and Application</b> .....	1
<b>1. Truck Description</b> .....	2
1.1 Application.....	2
1.2 truck Assemblies.....	3
1.2.1 Control Handle.....	4
1.2.2 Key switch.....	4
1.2.3 Battery discharge indicator.....	5
1.3 Standard Version Specifications.....	6
1.3.1 Performance data for standard trucks.....	6
1.3.2 Dimensions.....	7
1.4 Identification points and data plates.....	9
1.4.1 truck data plate.....	10
1.4.2 Capacity chart .....	11
<b>2. Commissioning</b> .....	12
2.1 Using the truck for the First Time.....	12
2.2 During brake-in.....	12
<b>3. Operation</b> .....	13
3.1 Safety Regulations for the Operation of trucks.....	13
3.2 Operate and run the truck.....	14
3.2.1 Preparing.....	14
3.2.2 Travel, Steering, Braking.....	14
3.2.3 Lifting, transporting and depositing loads.....	16
3.2.4 Parking the truck securely.....	17
<b>4. Battery Maintenance &amp; Charging</b> .....	18
4.1 Safety regulations for handling acid batteries.....	18
4.2 Battery type & dimension.....	18
4.3 Charging the battery.....	18
4.4 Battery removal and installation.....	19
4.5 Battery maintenance.....	20
4.6 Battery Disposal.....	20
<b>5. Truck Maintenance</b> .....	21
5.1 Operational safety and environmental protection.....	21
5.2 Maintenance Safety Regulations.....	21
5.3 Servicing and inspection.....	22
5.3.1 Maintenance Checklist.....	23
5.3.2 Lubrication Schedule.....	24
5.3.3 Maintenance Instructions.....	25

5.4Decommissioning the truck.....	26
5.4.1Prior to decommissioning.....	26
5.4.2 Restoring the truck to operation after decommissioning.....	27
5.5Safety checks to be performed at regular intervals and following any unusual incidents.....	27
5.6Final de-commissioning, disposal.....	28
<b>6.Troubleshooting.....</b>	<b>29</b>

## **Correct use and Application**

The "Guidelines for the Correct Use and Application of Industrial Trucks" (VDMA) are supplied with the truck. The guidelines is an important component of these operating instructions and must be observed. Your country's relevant laws and regulations is not affected.

The truck described in the present operator manual is an industrial truck designed for lifting and transporting load units.

It must be used, operated and serviced in accordance with the present instructions. Any other type of use is beyond the scope of application and can result in damage to personnel, the truck or property. In particular, avoid overloading the truck with loads which are too heavy or placed on one side. The data plate attached to the truck or the load diagram are binding for the maximum load capacity. The truck must not be used in fire or explosion endangered areas, or areas threatened by corrosion or excessive dust.

### **Proprietor responsibilities**

For the purposes of the present operator manual the "proprietor" is defined as any natural or legal person who either uses the truck himself, or on whose behalf it is used. In special cases (e.g. leasing or renting) the proprietor is considered the person who, in accordance with existing contractual agreements between the owner and user of the truck, is charged with operational duties.

The proprietor must ensure that the truck is used only for the purpose it is intended for and that danger to life and limb of the user and third parties are excluded.

Furthermore, accident prevention regulations, safety regulations and operating, servicing and repair guidelines must be followed. The proprietor must ensure that all truck users have read and understood this operator manual.

Failure to comply with the operator manual shall invalidate the warranty. The same applies if improper work is carried out on the truck by the customer or third parties without the permission of the manufacturer's customer service department.

### **Adding accessories**

The mounting or installation of additional equipment which affects or enhances the performance of the truck requires the written permission of the manufacturer. Local authority approval may also need to be obtained.

Local authority approval does not however constitute the manufacturer's approval.

## 1. truck Description

### 1.1 Application

The truck is tiller guided electric truck with a steered drive wheel.

It is designed for use on level floors to lift and transport palletised goods. Open bottom pallets or roll cages can be lifted.

The capacity can be obtained from the data plate.

The capacity with respect to lift height and load center of gravity is indicated on the capacity plate.

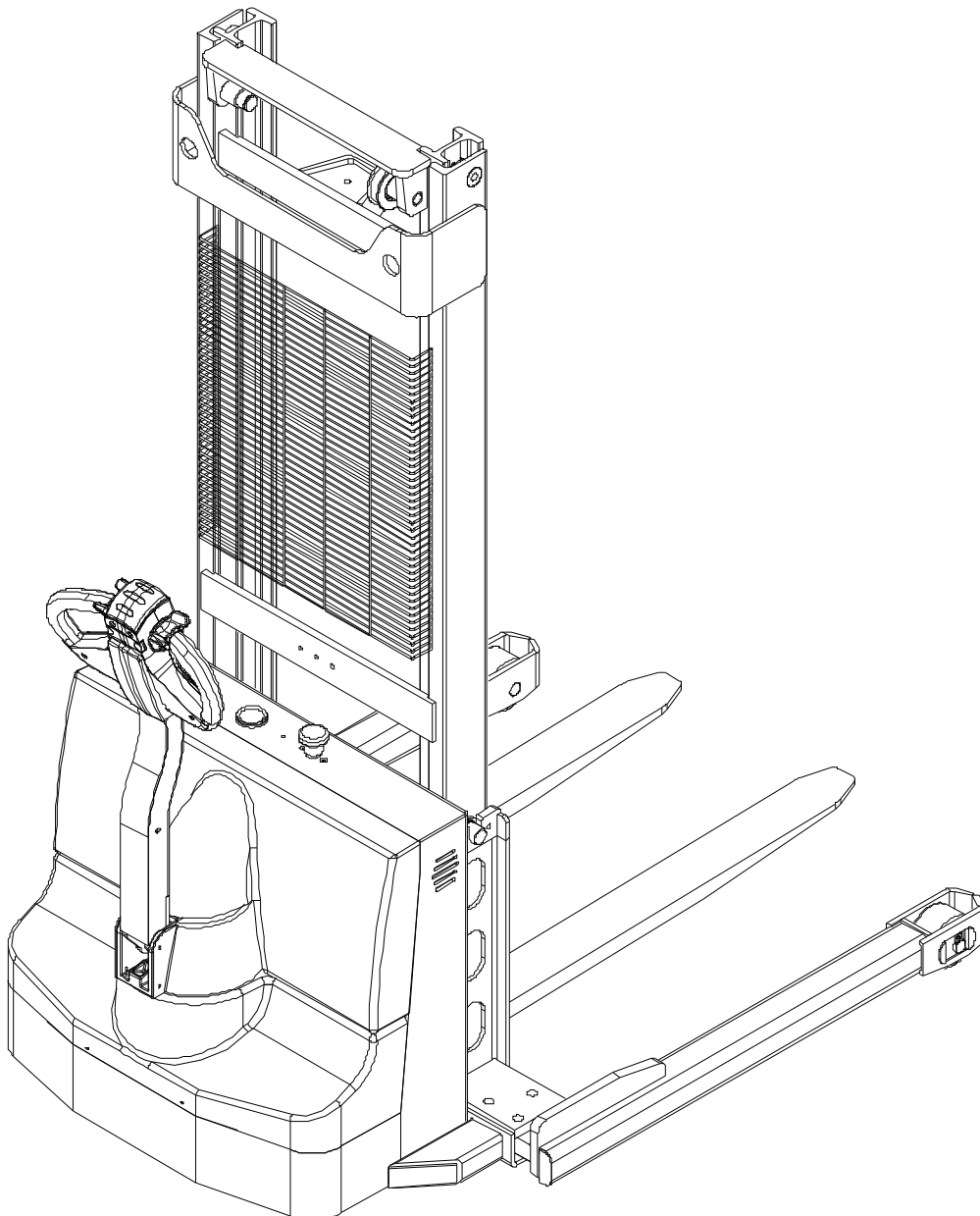



## 1.2 Truck Assemblies

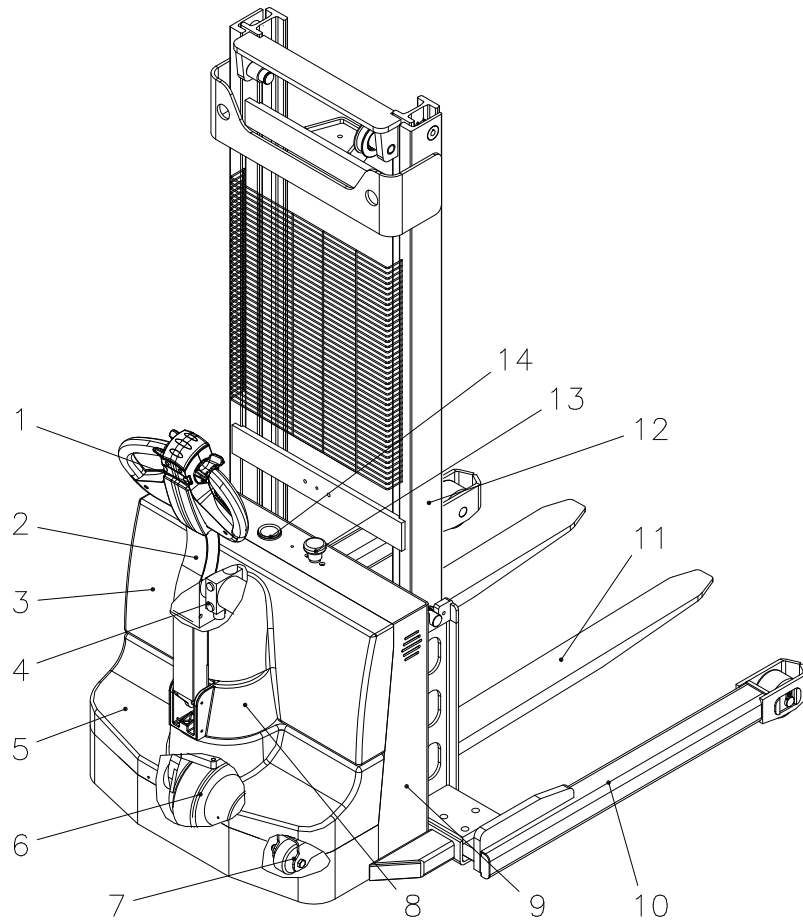

Item	Component	Item	Component
1	Handle assembly	7	Balance wheel assembly
2	Handle rod	8	Cover
3	Cover	9	Rear body
4	Hydraulic pump assembly	10	Support leg
5	Cover	11	Fork
6	Drive wheel assembly	12	Mast
		13	Emergency stop button
		14	BDI

### 1.2.1 Control Handle

Item	Component	Function
15	Collision switch	Safety function which, when activated, forces the truck to reverse until the switch restored to neutral.
16	Travel switch	Controls the driving speed and direction.
17	"Lower" button	Lowers fork.
18	"Lift" button	Raises fork frame.
19	Warning signal button	Triggers a warning signal.

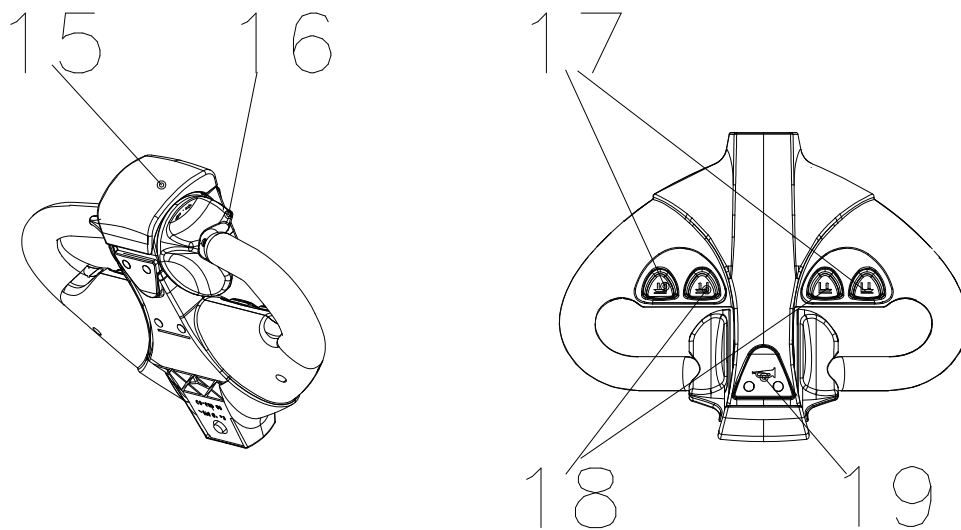

### 1.2.2 Key switch

Switches control current on and off.  
 Removing the key prevents the truck from being switched on by unauthorised personnel.

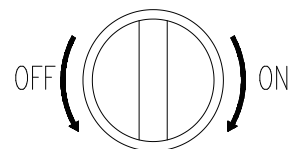

### 1.2.3 Battery discharge indicator

The LEDs (1) represent battery residual capacity, The LCD (2) displays the operating hours.

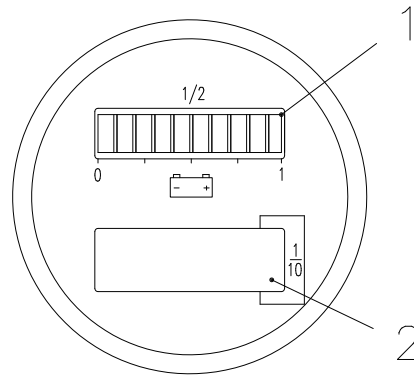

#### Battery Discharge Indicator(1)

When the truck has been released via the key switch, the battery charge status is displayed.

Every column means 10% Two electric bars show on battery charge used up warning. The battery must be charged.

#### Operating hours display(2)

Display range between 0.0 and 99,999.0 hours. Travel and lifting are logged. This is a backlit display.

Power up test

On power up the display shows:

- the operating hours
- the charge status

### 1.3 Standard Version Specifications

Technical specification details in accordance with JB/T3773.1-84.

Technical modifications and additions reserved.

#### 1.3.1 Performance data for standard trucks

	Model		WS10SS	WS12SS	WS15SSL	
			Straddle leg stacker			
characteristics	1.1	Type of drive		Full Electric	Full Electric	Full Electric
	1.2	Operator type		walkie	walkie	walkie
		Operating handle position		Middle	Middle	Middle
	1.3	Capacity	Q kg	1000	1200	1500
	1.4	Load center	C mm	600	600	600
	1.5	Wheel base	y mm	1230	1230	1230
wheel	2.1	Wheel type		PU	PU	PU
	2.2	Size of front wheels	mm	∅100x60	∅100x60	∅100x60
	4.1	Size of drive wheels	mm	∅210x75	∅210x75	∅210x75
	5.1	Size of balance wheels	mm	∅70x35	∅70x35	∅70x35
	6.1	Wheels quantity	pcs	1+2+2	1+2+2	1+2+2
	specifications	4.1	Mast lower height	mm	2095/1565/1815/2065 /2215/2235	2075/1515/1765/2015 /2165/2265
4.2		Mast extend height	mm	2480/2880/3380/3880/ 4180/4380	2490/2880/3380/3880/4 180/4380	2480/2880/3380/3880 0/4180/4380
4.3		Lifting height	mm	1600/2000/2500/3000/3300/3500		
4.5		Overall length	mm	1690/1690/1690/1690/ 1690/1705	1680/1705/1705/1705/1 705/1705	1705
4.6		Single fork width	mm	100	100	100
4.7		Rear body width	mm	820	820	820
4.8		Fork length	mm	1070	1070	1070
4.9		Inner width of fork(leg width+180)	mm	970/1110/1250		
4.10		Outer width of the fork	mm	200~800	200~800	200~800
4.11		Lowered height of fork	mm	70	70	70
4.12		Clearance	mm	30	30	30
4.13		Min.Turning radius	mm	1425	1425/1445/1445/1445/1 445	1425/1445/1445/1445 5/1445
4.14		Rear body height	mm	730	730	730
4.15		Aisle width (800*1200mm pallet):	mm	2530		
4.165		Aisle width (1000*1200mm pallet):	mm	2600		

<b>weight</b>	2.1	Service weight without battery	kg	530/540/560/580 /600/620	550/560/580/600 /620/640	570/580/600/620/64 0/660	
	2.2	Service weight with battery	kg	580/590/610/630 /650/670	600/610/630/650 /670/690	620/630/650/670/69 0/710	
<b>performance</b>	5.1	Travel speed	laden	km/h	3.5		
			unladen	km/h	4		
	5.2	Lift speed	laden	mm/s	100	100	75
			unladen	mm/s	112	112	90
	5.3	lower speed	laden	mm/s	92	92	85
			unladen	mm/s	85	85	75
	5.4	Gradeability	laden	%	5	5	5
			unladen	%	7	7	7
<b>Electric engine</b>	6.1	Drive motor	Kw	DC 0.65			
	6.2	Lift motor	Kw	2.2			
	6.3	Battery voltage/capacity(20h)	V/Ah	(12V/85Ah)×2			
	6.4	Battery size	mm	(260×172×214)×2			
	7.4	Brake type		Electromagnetic			
	8.4	Controller		1212P-2501 (CURTIS)			

WS10SS&WS12SS&WS15SSL

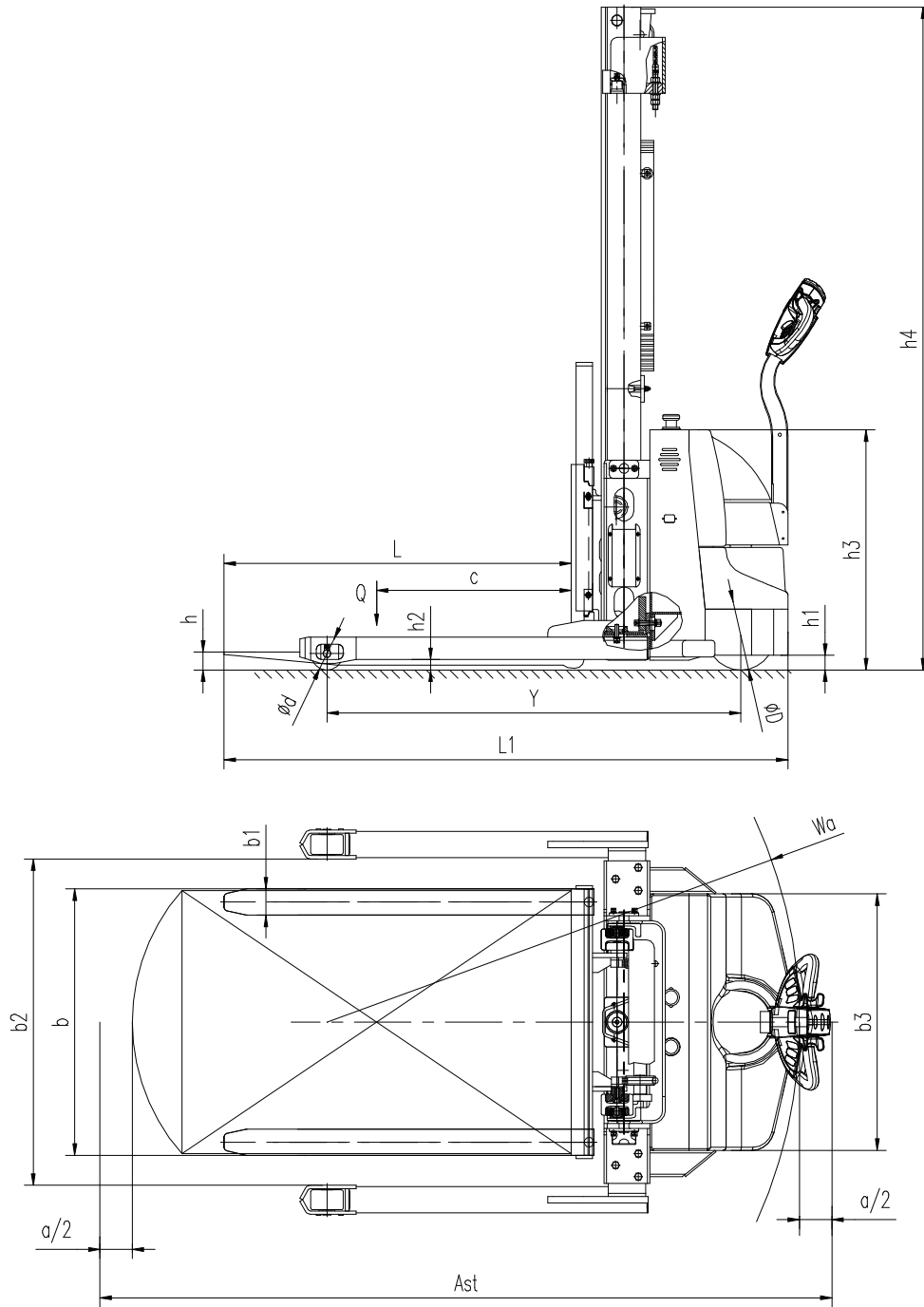

## 1.4 Identification points and data plates

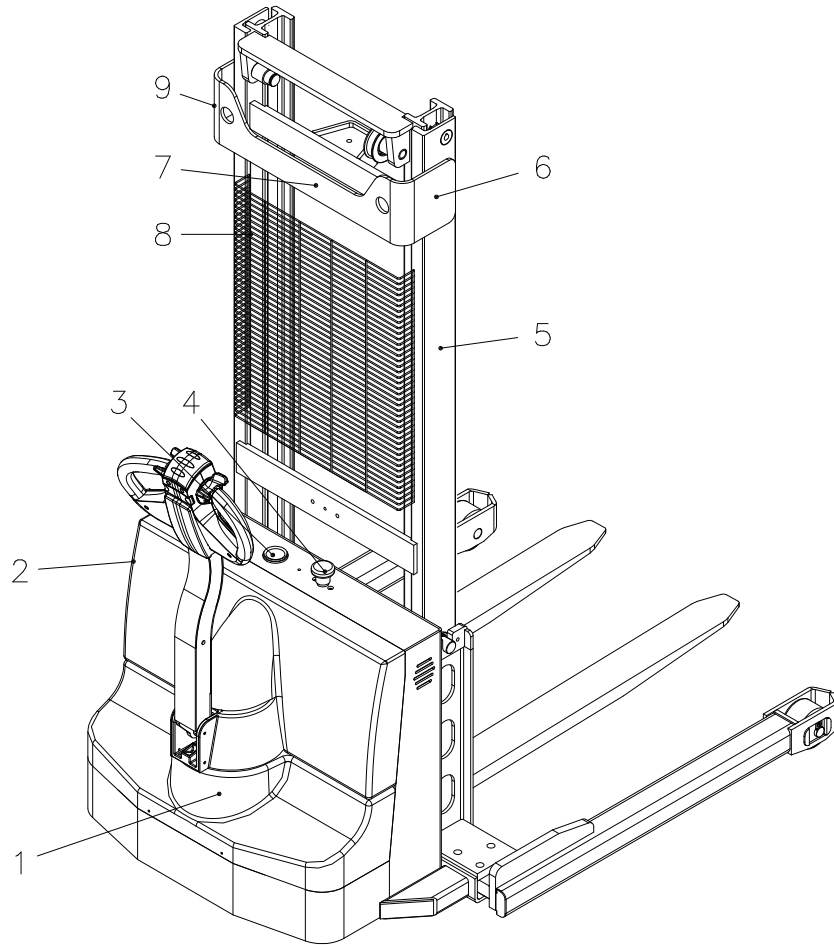

1		4		7	Capacity: <b>1500kg</b>
2		5		8	
3		6		9	





### 1.4.2 Capacity chart

The chart given above shows the relation between the load center and the weight of loads.

WS10SS

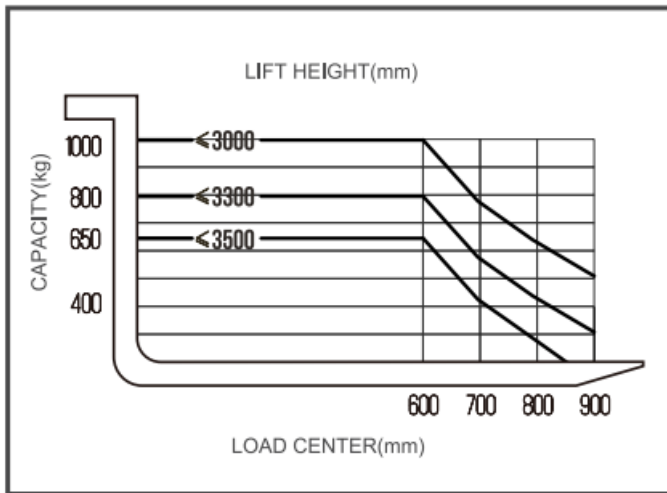

WS12SS

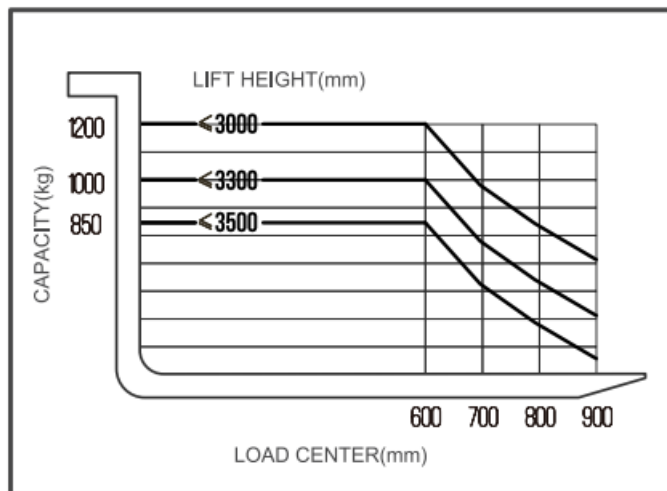

WS15SSL

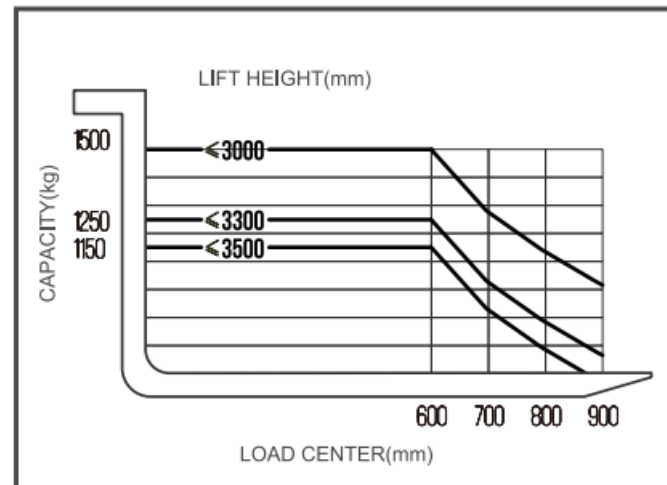

## **2. Commissioning**

### **2.1 Using the truck for the First Time**

Only operate the truck with battery current.

Preparing the truck for operation after delivery or transport.

Procedure

- Check the equipment is complete.
- Check the hydraulic oil level.
- Install the battery if necessary (where required), (see "4.4 Battery removal and installation" on page 18) do not damage battery cable.
- Charge the battery, (see "4.3 Charging the battery" on page 17).

When the truck is parked the surface of the tyres will flatten. The flattening will disappear after a short period of operation.

### **2.2 During brake-in**

We recommended operating the machine under light load conditions for the first stage of operation to get the most from it. Especially the requirements given below should be observed while the machine is in a stage of 100 hours of operation.

- Must prevent the new battery from over discharging when early used. Please charging when remain power less than 20%.
- Perform specified preventive maintenance services carefully and completely.
- Avoid sudden stop, starts or turns.
- Oil changes and lubrication are recommended to do earlier than specified.
- Limited load is 70~80% of the rated load.

### 3.Operation

#### 3.1 Safety Regulations for the Operation of trucks

Driver authorisation: The truck may only be used by suitably trained personnel, who have demonstrated to the proprietor or his representative that they can drive and handle loads and have been authorised to operate the truck by the proprietor or his representative.

**Driver's rights, obligations and responsibilities:** The driver must be informed of his duties and responsibilities and be instructed in the operation of the truck and shall be familiar with the operator manual . The driver shall be afforded all due rights . Safety shoes must be worn with pedestrian operated trucks.

**Unauthorised Use of truck:** The driver is responsible for the truck during the time it is in use. He shall prevent unauthorised persons from driving or operating the truck. It is forbidden to carry passengers or lift personnel.

Damage and Faults: The supervisor must be immediately informed of any damage or faults to the truck. trucks not safe for operation (e.g. wheel or brake problems) must not be used until they have been rectified.

**Repairs:** The driver must not carry out any repairs or alterations to the truck without the necessary training and authorisation to do so. The driver must never disable or adjust safety mechanisms or switches.

**Hazardous area:** A hazardous area is defined as the area in which a person is at risk due to truck movement, lifting operations, the load handler (e.g. forks or attachments) or the load itself. This also includes areas which can be reached by falling loads or lowering operating equipment.

- Unauthorised persons must be kept away from the hazardous area.
- Where there is danger to personnel, a warning must be sounded with sufficient notice.
- If unauthorised personnel are still within the hazardous area the truck shall be brought to a halt immediately.

**Safety Devices and Warning Signs:** Safety devices, warning signs and warning instructions shall be strictly observed.

## 3.2 Operate and run the truck

### 3.2.1 Preparing

Before the truck can be commissioned, operated or a load unit lifted, the driver must ensure that there is nobody within the hazardous area.

#### Checks and operations to be performed before starting daily work

- Visually inspect the entire truck (in particular wheels and load handler) for obvious damage.

### 3.2.2 Travel, Steering, Braking

Do not drive the truck unless the panels are closed and properly locked.

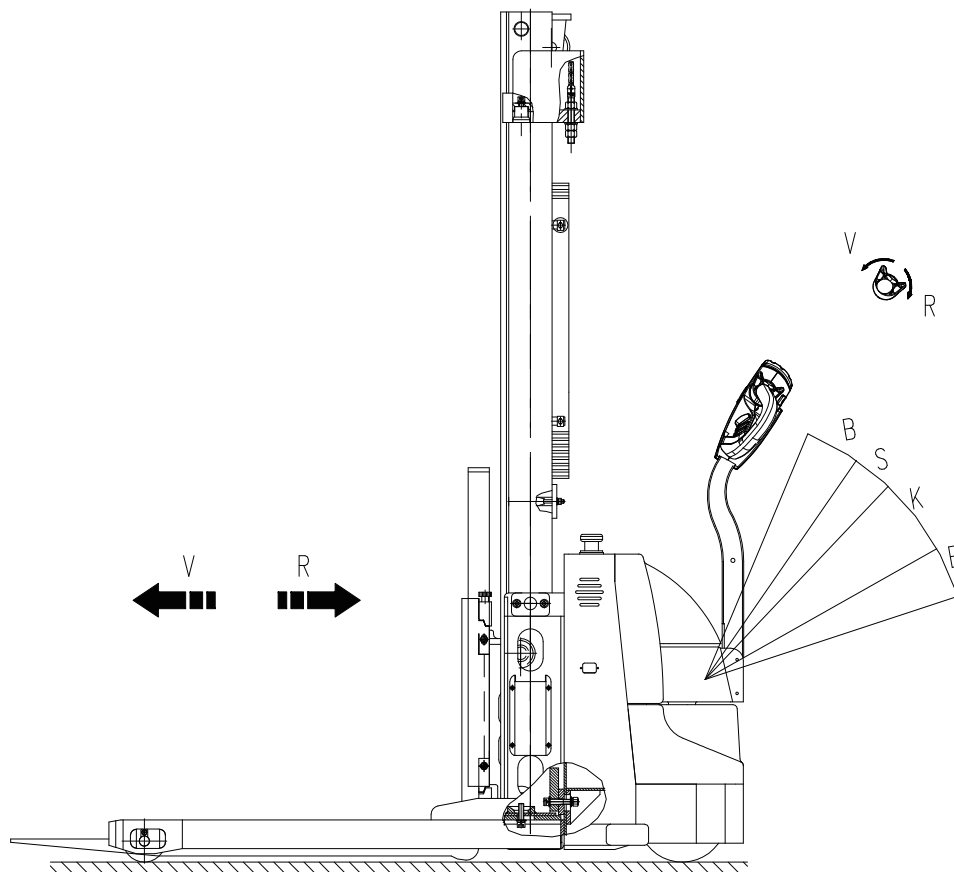

## 1. Driving

### Driving in low speed

Push the control shaft into the slow speed range (S) and set the driving switch to the desired driving direction (front or back). The bigger angle it swivels, the higher speed will it get.

### 3.2.3 Lifting, transporting and depositing loads

#### Unsecured and incorrectly positioned loads can cause accidents

- Instruct other people to move out of the hazardous area of the truck. Stop working with the truck if people do not leave the hazardous.

- Only carry loads that have been correctly secured and positioned. Use suitable precautions to prevent parts of the load from tipping or falling down.

- Do not transport witch bad handbarrow (as truck and stock) .

- Never stand underneath a raised load

- handler. •Do not stand on the load handler.

- Do not lift other people on the load handler.

- Insert the forks as far as possible underneath the load.

#### Warning!

Before lifting a load unit the driver must make sure that it has been correctly stowed and does not exceed the truck's capacity.

Do not lift long loads at an angle.

#### Lift

Press "Lift" button(18) until the height you need.

#### Lower

Press "Lower" button (17) until the lowest position.

#### Warning!

Don't lift to tiptop, to avoid shorted life of oil cylinder.

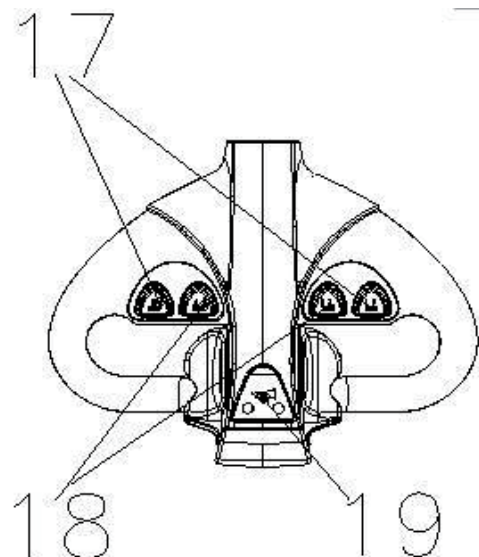
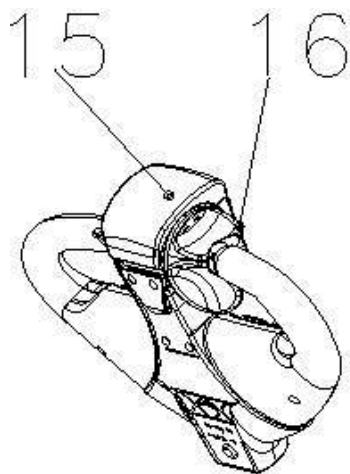

## Driving in high speed

Push the control shaft into the quick speed range(K) and set the driving switch to the desired driving direction(front or back). The bigger angle it swivels,the higher speed will it get.

It will get different speed though the switch swivels the same angle in the different range,the speed in the quick range(K) is quicker than in the slow range(S).

## 2.Steering

Apply the control handle(2) to the left or right.

## 3.Braking

The brake pattern of the truck depends largely on the ground conditions. The driver must take this into account when operating the truck.

The driver must be looking ahead when traveling. If there is no hazard, brake moderately to avoid moving the load .

The truck can brake in four different ways:

- Emergency braking
- Automatic braking
- Regenerative braking
- Inversion braking

### • Emergency braking

Press the emergency brake switch(1), all electrical functions are cut out and the truck automatically brakes.

### • Automatic braking

When the control handle(2) is released it automatically sets itself to the upper brake zone (B) and automatic braking ensues.

### • Regenerative braking

If the travel switch (16) (see Page 4) is set to "0", the truck automatically brakes regeneratively. When the speed below 1Km/h the brake then applies and motor brake stop.

### • Inversion braking

You can set the travel switch (16) (see Page 4) to the opposite direction when traveling. The truck brakes regeneratively until it starts to move in the opposite direction.

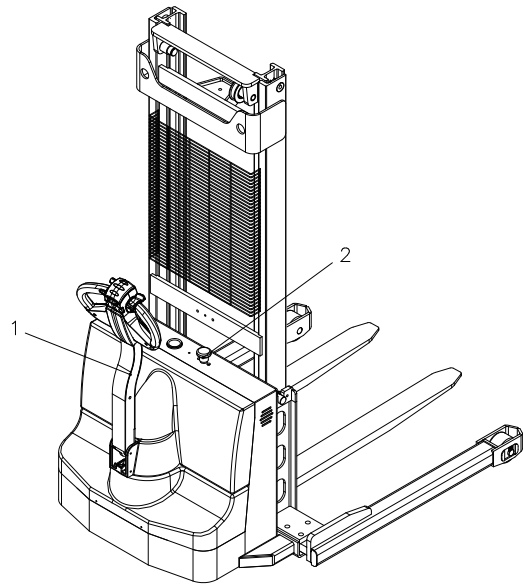

### Warning!

If the control handle moves slowly or not at all to the upper brake zone, the truck must be taken out of service until the cause of this fault is be rectified.  
Replace the gas pressure spring if necessary.

### Warning!

If the travel switch moves slowly or not at all to 0, the truck must be taken out of service until the cause of this fault is be rectified.  
Replace the control handle if necessary.

### Warning!

In hazardous situations set the control handle to the brake position or set the travel switch (14) to the opposite direction.

### 3.2.4 Parking the truck securely

When you leave the truck it must be securely parked even if you only intend to leave it for a short time.

- Press “Lower” button(17) , fully lower the load handler.
- Fully lower the forks.
- Press the emergency brake switch(1).

#### **Warning!**

Parking the truck securely.  
Forbid parking on an incline.  
Always fully lower the forks.

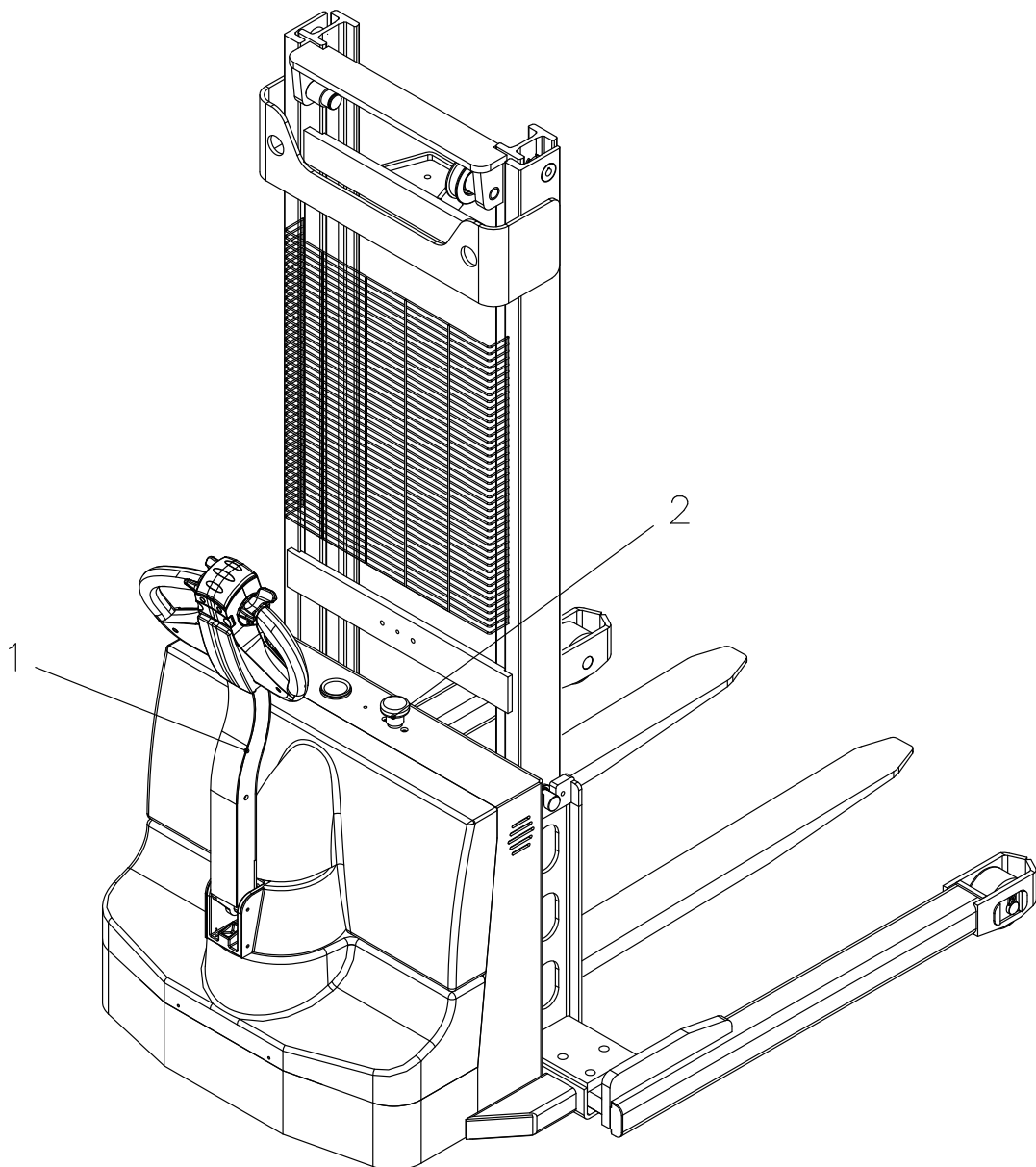

## 4. Battery Maintenance & Charging

### 4.1 Safety regulations for handling acid batteries

Park the truck securely before carrying out any work on the batteries.

**Maintenance personnel :** Batteries may only be charged, serviced or replaced by trained personnel .The present operator manual and the manufacturer 's instructions concerning batteries and charging stations must be observed when carrying out the work.

#### Fire protection :

- Smoking and naked flames must be avoided when working with batteries.
- Wherever a truck is parked for charging there shall be no inflammable material or operating fluids capable of creating sparks within 2 meters around the truck.
- The area must be well ventilated.
- Fire protection equipment must be provided.



#### Protection against electric shock:

- Battery has high voltage and energy.
- Do not bring short circuit.
- Do not approach tools to the two poles of the battery, which can cause the sparkle.

### 4.2 Battery type & dimension

Battery type & dimension as follow :

Tuck type	Battery type	voltage/ rated capacity (V/Ah)	Battery height (mm)	Battery length (mm)	Battery width (mm)
WS10/12SS/15SSL	Industry battery	2×12V/75	260	169	215

When replacing or installing batteries, ensure that the battery is correctly secured in the battery compartment of the truck.

### 4.3 Charging the battery

#### Safety regulations for Charging the battery

- To charge the battery, the truck must be parked in a closed and properly ventilated room.
- Do not place any metal objects on the battery.
- Before charging, check all cables and plug connections for visible signs of damage.
- Before start and finish charging to make sure power is turn OFF.
- It is essential to follow the safety regulations of the battery and charging station



manufacturers.

### Charging step

- Check whether the condition is according with "Safety regulations for Charging the battery".
- Park the truck securely(See 3.2.4 Parking the truck securely Page21).
- Remove the battery plug .
- Connect the battery plug with the charging lead of the stationary charger and turn on the charger.

LED lamp :

- Yellow light : the battery is charging.
- Green light : the battery is fully charged.
- Red light : Batteries failure.

### Warning!

Mains voltage:100-240V

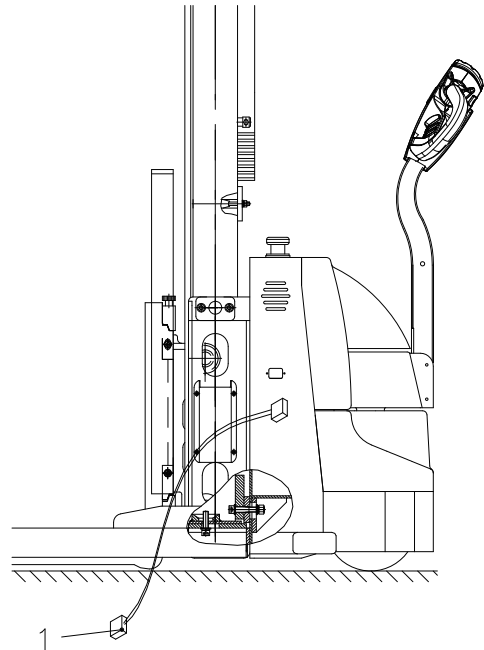

### 4.4 Battery removal and installation

Park the truck securely and turn off the power before removal and installation battery.

Battery removal and installation steps:

- a: Remove screws(1), take out the side plate(2&3).
- b: Remove battery cables .
- c: Put battery in or removal battery.

• Installation is in the reverse order of operations, pay attention on battery install position and cable connection. Make sure the well place cables to avoid be damaged when you removal and installation battery.

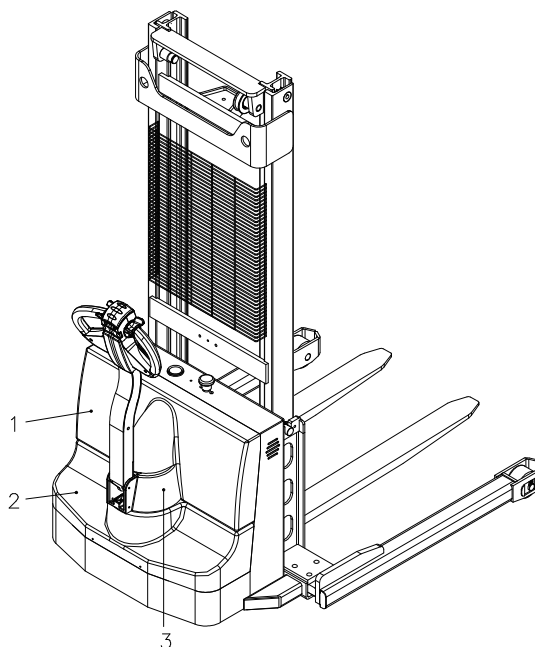

## 4.5 Battery maintenance

### Do not overuse battery:

- If you use up the energy of battery till the forklift immovability, you will shorten its working hours.
- Shower for battery appears need for charge, please charge it quickly.

### Battery maintenance:

The battery cell covers must be kept dry and clean. The terminals and cable shoes must be clean, secure and have a light coating of dielectric grease. Batteries with non insulated terminals must be covered with a non slip insulation mat.

#### Warning!

1. Do not use dry cloth or fibre cloth to clean the battery, avoiding static to bring the explosion.
2. Unfixing battery plug.
3. Cleaning with wet cloth.
4. Wearing glasses for protecting eyes rubber overshoes and rubber glove.

### Battery storage:

If batteries are taken out of service for a lengthy period they should be stored in the fully charged condition in a dry, frost-free room. To ensure the battery is always ready for use a choice of charging methods can be made:

- a monthly equalizing charge as in point 4.3(see Page 17)

## 4.6 Battery Disposal

Batteries may only be disposed of in accordance with national environmental protection regulations or disposal laws. The manufacturer's disposal instructions must be followed.

Batteries contain an acid solution which is poisonous and corrosive . Therefore , always wear protective clothing and eye protection when carrying out work on batteries . Above all avoid any contact with battery acid.

Nevertheless, should clothing, skin or eyes come in contact with acid the affected parts should be rinsed with plenty of clean water-where the skin or eyes are affected call a doctor immediately. Immediately neutralise any spilled battery acid.

Only batteries with a sealed battery container may be used.

The weight and dimensions of the battery have considerable affect on the operational safety of the truck. Battery equipment may only be replaced with the agreement of the manufacturer.

## **5. truck Maintenance**

### **5.1 Operational safety and environmental protection**

- The servicing and inspection operations contained in this chapter must be performed in accordance with the intervals indicated in the servicing checklists.
- Any modification to the truck assemblies, in particular the safety mechanisms, is prohibited. The operational speeds of the truck must not be changed under any circumstances.
- Only original spare parts have been certified by our quality assurance department. To ensure safe and reliable operation of the truck, use only the manufacturer's spare parts. Used parts, oils and fuels must be disposed of in accordance with the relevant environmental protection regulations. For oil changes, contact the manufacturer's specialist department.
- Upon completion of inspection and servicing, carry out the activities listed in the "Recommissioning (on page 25)" section.

### **5.2 Maintenance Safety Regulations**

#### **Maintenance personnel**

trucks must only be serviced and maintained by the manufacturer's trained personnel. The manufacturer's service department has field technicians specially trained for these tasks. We therefore recommend a maintenance contract with the manufacturer's local service center.

#### **Lifting and jacking up**

When a truck is to be lifted, the lifting gear must only be secured to the points specially provided for this purpose.

When jacking up the truck, take appropriate measures to prevent the truck from slipping or tipping over (e.g. wedges, wooden blocks).

You may only work underneath a raised load handler if it is supported by a sufficiently strong chain.

#### **Cleaning**

Do not use flammable liquids to clean the truck.

Prior to cleaning, all safety measures required to prevent sparking (e.g. through short circuits) must be taken. For battery-operated trucks, the battery connector must be removed.

Only weak suction or compressed air and non-conductive antistatic brushes may be used for cleaning electric or electronic assemblies.

If the truck is to be cleaned with a water jet or a high-pressure cleaner, all electrical and electronic components must be carefully covered beforehand as moisture can cause malfunctions.

Do not clean with pressurised water.

After cleaning the truck, carry out the activities detailed in the “Recommissioning (on page 25)” section.

### **Electrical System**

Only suitably trained personnel may operate on the truck’s electrical system.

Before working on the electrical system, take all precautionary measures to avoid – electric shocks.

For battery-operated trucks, also de-energise the truck by removing the battery connector.

### **Welding**

To avoid damaging electric or electronic components, remove these from the truck before performing welding operations.

### **Settings**

When repairing or replacing electric or electronic components or assemblies, always note the truck-specific settings.

### **Tyres**

The quality of tyres affects the stability and performance of the truck. When replacing factory fitted tyres only used original manufacturer’s spare parts, as otherwise the data plate specifications will not be kept.

When changing wheels and tyres, ensure that the truck does not slew (e.g. when replacing wheels always left and right simultaneously).

### **5.3 Servicing and inspection**

Thorough and expert servicing is one of the most important requirements for the safe operation of the truck. Failure to perform regular servicing can lead to truck failure and poses a potential hazard to personnel and equipment.

The service intervals stated are based on single shift operation under normal operating conditions. They must be reduced accordingly if the truck is to be used in conditions of extreme dust, temperature fluctuations or multiple shifts.

The following maintenance checklist states the tasks and intervals after which they should be carried out. Maintenance intervals are defined as:

W = Every 50 service hours, at least

weekly A = Every 250 operating hours

B = Every 500 operating hours, or at least annually C

= Every 2000 operating hours, or at least annually

W service intervals are to be performed by the customer.

In the run-in period - after approx. 100 service hours - or after repair work, the owner must check the wheel nuts/bolts and re-tighten if necessary.

### 5.3.1 Maintenance Checklist

		Maintenance interval ●			
		W	A	B	C
Braking	Check magnetic brake air gap.			●	
Electrical system	Test instruments, displays and control switches.	●			
	Test warning and safety device.		●		
	Make sure wire connections are secure and check for damage.			●	
	Test micro switch setting.	●			
	Check relays.			●	
	Fix the motor and cable			●	
Power supply	Visually inspect battery		●		
	Visually inspect battery plug			●	
	Check battery cable connections are secure, grease terminals if necessary.			●	
Travel	Check the transmission for noise and leakage.			●	
	Check travel mechanism, adjust and lubricate if necessary. Check control handle recuperating function.		●		
	Check wheels for wear and damage.			●	
	Check wheel bearings and attachments.			●	
truck frame	Check truck frame for damage.			●	
	Check labels are present and complete			●	
	Check mast attachment			●	
Hydraulic operations	Test hydraulic system.		●		
	Check that hose and pipe lines and their connections are secure, check for leaks and damage.		●		
	Check cylinders and piston rods for damage and leaks, and make sure they are secure.			●	
	Check load chain setting and tension if necessary.			●	
	Visually inspect mast rollers and check contact surface wear level			●	
	Check forks, load handler for wear and damage			●	
	Check hydraulic oil level.			●	
	Replace hydraulic oil.				●
	Check and clean hydraulic oil filter. Replace it if necessary.				●

### 5.3.2 Lubrication Schedule

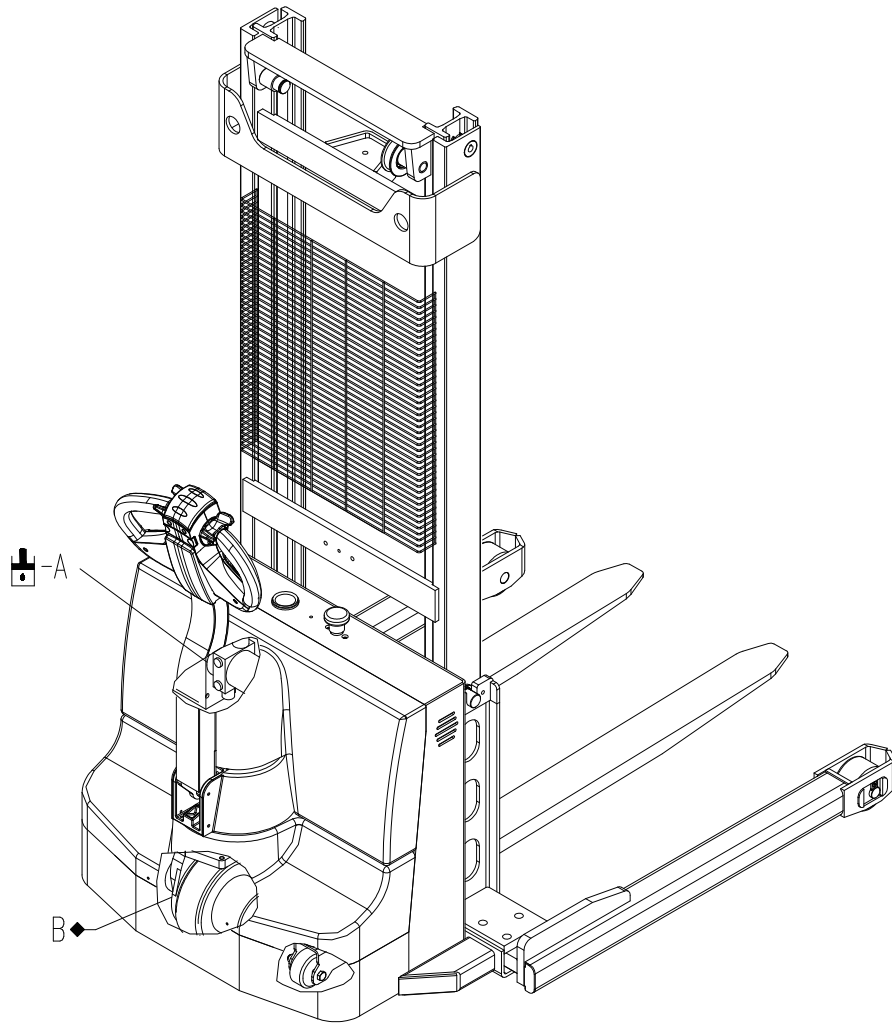

⊞ Hydraulic oil filler neck

◆ Transmission oil filler neck

## Consumables

Handling consumables type material: Consumables must always be handled correctly. Follow the manufacturer's instructions.

Improper handling is hazardous to health, life and the environment. Consumables must only be stored in appropriate containers. They may be flammable and must therefore not come into contact with hot components or naked flames.

Only use clean containers when filling up with consumables. Do not mix consumables of different grades. The only exception to this is when mixing is expressly stipulated in the Operating Instructions.

Avoid spillage. Spilled liquids must be removed immediately with suitable bonding agents and the bonding agent/consumable mixture must be disposed of in accordance with regulations.

Code	Description	Used for
A	HM46#	Hydraulic system
B	GL-85W-90	Gear case

### 5.3.3 Maintenance Instructions

#### Prepare the truck for maintenance and repairs

All necessary safety measures must be taken to avoid accidents when carrying out maintenance and repairs. The following preparations must be made:

- Park the truck securely (See 3.2.4 Parking the truck securely Page 16) .
- Remove the key to prevent the truck from accidentally starting.
- When working under a raised lift truck, secure it to prevent it from tipping or sliding away.

#### Open the cover(upper)

- Remove the 10 screws (1) .
- Carefully open the cover(2&3) .

#### Replacing the drive wheel

The drive wheel must only be replaced by authorised service personnel.

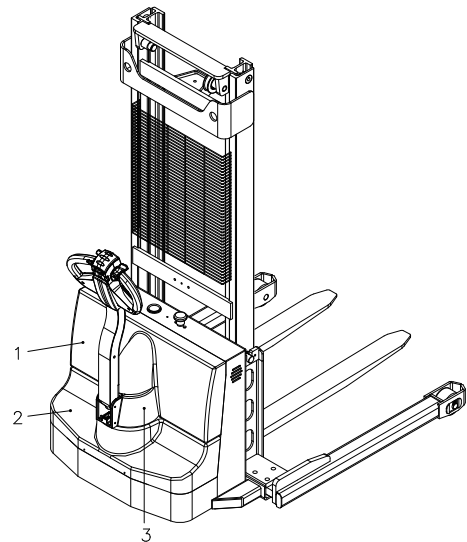

### Checking electrical fuses

- Prepare the truck for maintenance and repairs (See 5.3.3 Maintenance Instructions Page 24).
- Open the cover (upper) (See 5.3.3 Maintenance Instructions Page 24).
- Check rating of all fuses in accordance with table, replace if necessary.

Item	To protect:	Rating
1	Traction/Lift motor Fuse	200A
2	Controller Fuse	6A

### Recommissioning

The truck may only be recommissioned after cleaning or repair work, once the following operations have been performed.

- Test horn.
- Test Emergency brake switch.
- Test brake.
- Lubricate the truck in accordance with the maintenance schedule.

### 5.4 Decommissioning the truck

If the truck is to be decommissioned for more than two months, e.g. For operational reasons, it must be parked in a frost-free and dry location and all necessary measures must be taken before, during and after decommissioning as described.

On decommissioning the truck must be jacked up so that all the wheels are clear of the ground. This is the only way of ensuring that the wheels and wheel bearings are not damaged.

If the truck is to be out of service for more than 6 months, further measures must be taken in consultation with the manufacturer's service department.

#### 5.4.1 Prior to decommissioning

- Thoroughly clean the truck.
- Check the brakes.
- Check the hydraulic oil level and replenish as necessary (See 5.3.3 Maintenance Instructions P24).
- Apply a thin layer of oil or grease to any non-painted mechanical components.
- Lubricate the truck in accordance with the maintenance schedule (See 5.3.2 Lubrication Schedule P23).

#### **Warning !**

Charge every month:

- Charge the battery.

Battery powered trucks:

The battery must be charged at regular intervals to avoid depletion of the battery through self-discharge. The sulfatisation would destroy the battery.



- Charge the battery (See 4.3 Charging the battery P17).
- Disconnect the battery, clean it and apply grease to the terminals. In addition, follow the battery manufacturer's instructions.
- Spray all exposed electrical contacts with a suitable contact spray.

#### 5.4.2 Restoring the truck to operation after decommissioning

- Thoroughly clean the truck.
- Lubricate the truck in accordance with the maintenance schedule (See 5.3.2 Lubrication Schedule P23 ).
- Clean the battery, grease the terminals and connect the battery.
- Charge the battery (See 4.3 Charging the battery P17).
- Check hydraulic oil for condensed water and replace if necessary.
- Start up the truck (see 3.2 Operate and run the truck P13).

#### Battery powered trucks:

If there are switching problems in the electrical system, apply contact spray to the exposed contacts and remove any oxide layers on the contacts of the operating controls by applying them repeatedly.

Perform several brake tests immediately after re-commissioning the truck.

#### 5.5 Safety checks to be performed at regular intervals and following any unusual incidents

Carry out a safety check in accordance with national regulations. EP has a special safety department with trained personnel to carry out such checks. The truck must be inspected at least annually (refer to national regulations) or after any unusual event by a qualified inspector. The inspector shall assess the condition of the truck from purely a safety viewpoint, without regard to operational or economic circumstances. The inspector shall be sufficiently instructed and experienced to be able to assess the condition of the truck and the effectiveness of the safety mechanisms based on the technical regulations and principles governing the inspection of trucks.

A thorough test of the truck must be undertaken with regard to its technical condition from a safety aspect. The truck must also be examined for damage caused by possible improper use. A test report shall be provided. The test results must be kept for at least the next 2 inspections.

The owner is responsible for ensuring that faults are immediately rectified.

A test plate is attached to the truck as proof that it has passed the safety inspection.

This plate indicates the due date for the next inspection.

## 5.6 Final de-commissioning, disposal

Final, proper decommissioning or disposal of the truck must be performed in accordance with the regulations of the country of application. In particular, regulations governing the disposal of batteries, fuels and electronic and electrical systems must be observed.

## 6.Troubleshooting

This chapter is designed to help the user identify and rectify basic faults or the results of incorrect operation. When locating a fault, proceed in the order shown in the table.

Fault	Possible cause	Action
truck does not start.	<ul style="list-style-type: none"><li>• Key switch in “OFF” position</li><li>• Battery charge too low</li><li>• Faulty fuse</li><li>• truck in charge mode</li></ul>	<ul style="list-style-type: none"><li>• Set key switch to “I”</li><li>• Check battery charge, charge battery if Necessary</li><li>• Test fuses</li><li>• Interrupt charging</li></ul>
Load can not be lifted	<ul style="list-style-type: none"><li>• Hydraulic oil level too low</li><li>• Excessive load</li></ul>	<ul style="list-style-type: none"><li>• Check the hydraulic oil level</li><li>• Note maximum capacity (see data plate)</li></ul>

If the fault cannot be rectified after carrying out the remedial procedure, notify the manufacturer ’ s service department , as any further troubleshooting can only be performed by specially trained and qualified service personnel.

1	1	2	3	6				7
8		B-		4	7	8		14

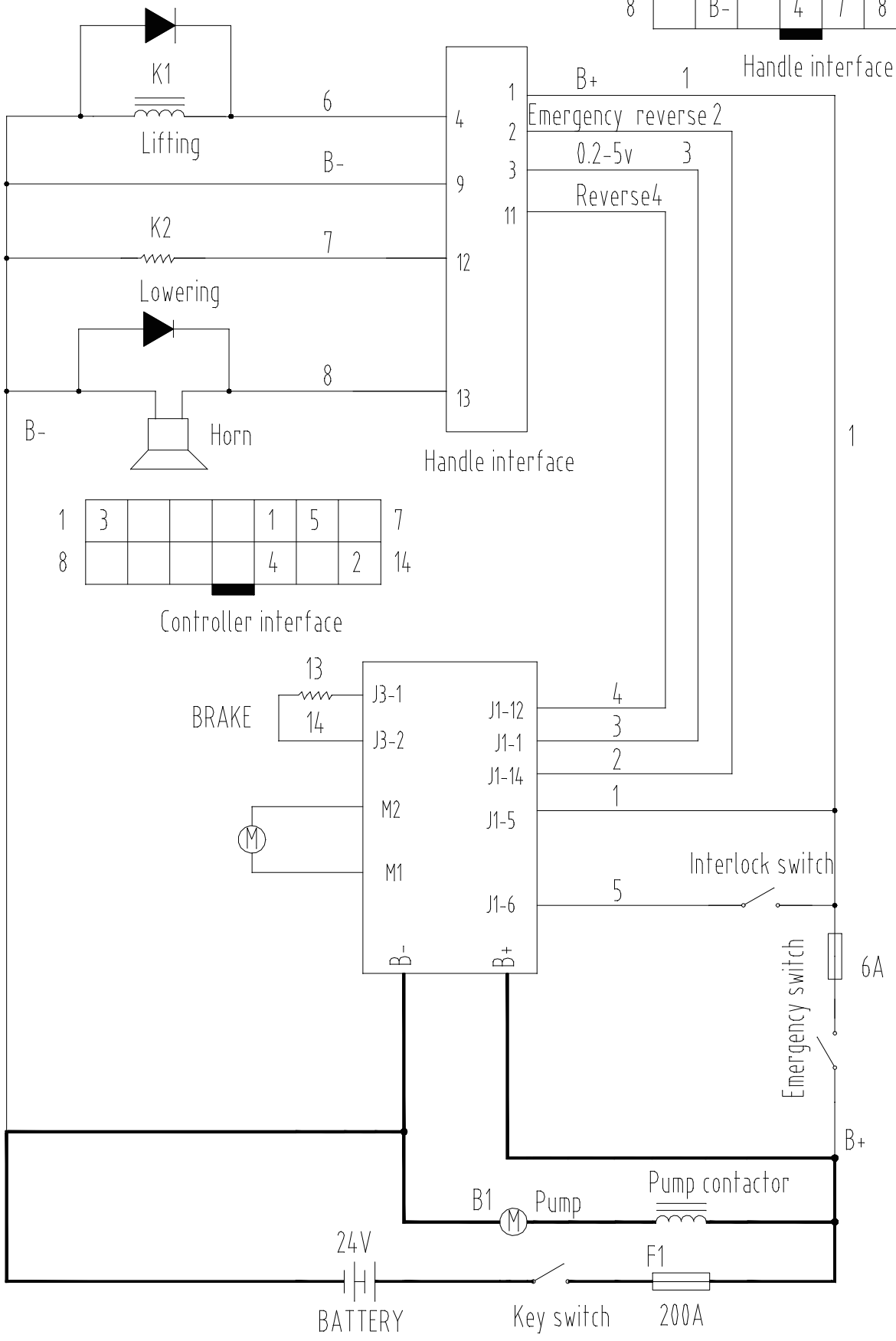

1	3				1	5		7
8					4			14

Controller interface

Handle interface

Handle interface

1

6A

B+

24V  
BATTERY

Key switch

F1  
200A

B1 Pump

Pump contactor

Interlock switch

Emergency switch

B-

Horn

Lowering

Lifting

K1

K2

B+ 1  
Emergency reverse 2  
0.2-5v 3  
Reverse 4

1  
4  
2  
9  
3  
11  
12  
13

6

B-

7

8

B+

1

Handle interface